

Thermafoil® Valve Stem Packing Data Sheet

Please complete the 2 steps below and email or fax to egc-ent.com. This information is **REQUIRED** for accurate design, quotation and manufacture of an EGC graphite pressure seal for your application. Incomplete, inaccurate or missing information will result in a delay or inability to design, quote or manufacture the required pressure seal.

Step 1: Customer & Valve Data

Company: _____ Contact Name: _____
 Plant: _____ Email: _____
 Valve Location: _____ Valve Manufacturer: _____
 Valve Size: _____ Valve Type: _____ Valve Figure No.: _____
 Phone: _____ Valve Pressure Class: _____ Qty. Required: _____

Step 2: Provide dimensions below using the stuffing box illustrations for reference.
ACCURATE & COMPLETE data is essential to ensure proper fit & function of a new Pressure Seal.

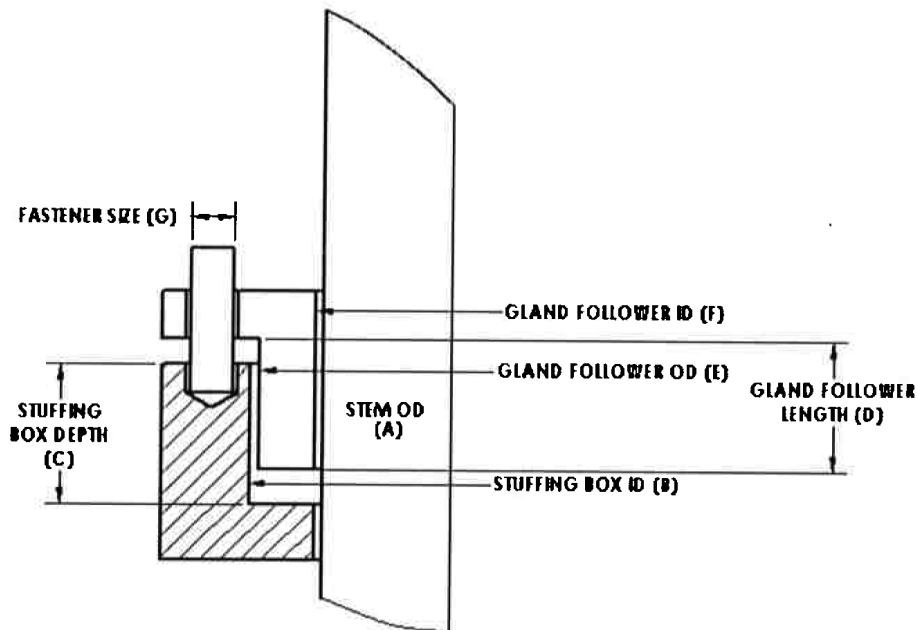

- | | |
|---|---|
| 1) What is the Valve Pressure Class _____ | 7) E) Glad Follower OD: _____ in. |
| 2) Operating Temperature? _____ °F | 8) F) Glad Follower ID: _____ in. |
| 3) A) Stem OD: _____ in. | 9) G) Fastener Size: _____ in. |
| 4) B) Stuffing Box ID: _____ in. | 10) Number of Fasteners: _____ in. |
| 5) C) Stuffing Box Depth: _____ in. | 11) Stem Motion: _____ in. |
| 6) D) Glad Follower Length: _____ in. | (Rotating or Rising or Rotating/Rising) |